

ALL-LITE

SSR-645

Extruded Aluminum Sunshade
6" deep • Rectangular Tube Blade

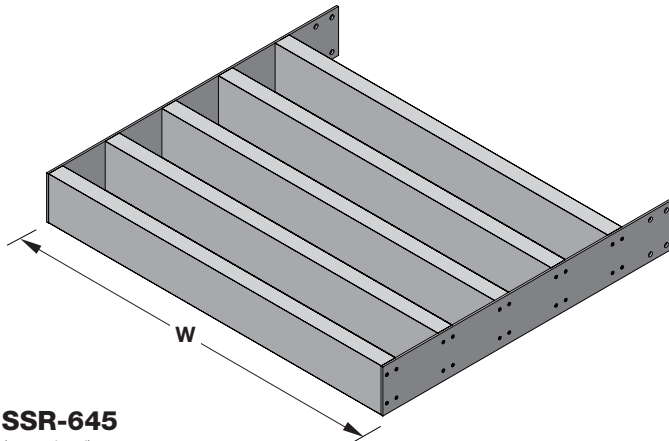

SSR-645

(standard)

*Dimensions furnished net O.D. (Centerline of mounting bracket to centerline of mounting bracket)

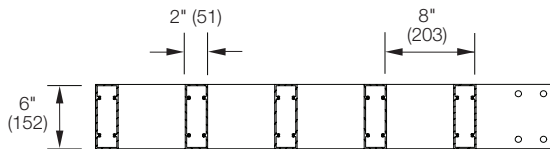

Horizontal Section

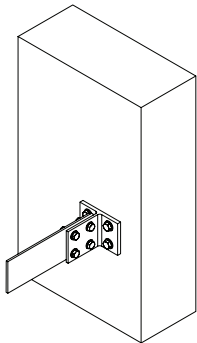

Exposed Mounting Bracket
(standard)

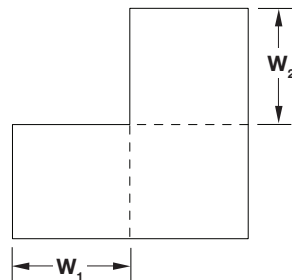

90° Corner

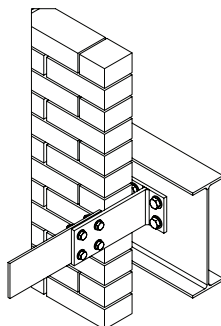

Concealed Mounting Bracket
(optional)

5 year
warranty

NOTE: Dimensions in parentheses () are millimeters.
Information is subject to change without notice or obligation.

The SSR-645 extruded aluminum sunshade is designed to provide distinctive style to a building's exterior while keeping the building cool and saving energy by reducing glare and thermal load. It is ideal for sustainable or 'green' building construction. The SSR-645 is available in a wide array of anodized and painted finishes including custom color matching.

Standard Construction

Material: Mill finish 6063-T5 extruded aluminum

Outrigger: 6" high × 0.250" thick (152 × 6.4) plate with flat front

Blades: 0.125" (3.2) thick rectangular tube style

Fascia: 6" × 2" × 0.125" thick (152 × 51 × 3.2) rectangular tube

Minimum Size: 12" wide (305)

Maximum Size: Single section: Consult Factory
Multiple section: Unlimited

Projection: 24" (610), 36" (914), 42" (1067), 48" (1219), and 60" (1524)

Mounting Bracket: Exposed

Options

■ Factory finish:

- High Performance Fluoropolymer - 100% resin Newlar®/70% resin Kynar®
- Clear Anodize
- Integral Color Anodize
- Baked Enamel

■ Tapered (top and bottom) outrigger

■ Concealed mounting bracket

■ Strut connection

■ Shroud connection

■ 90° corner

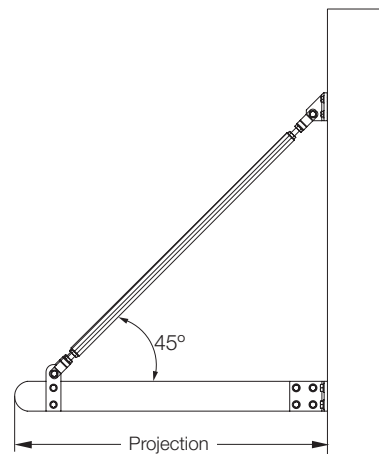

Shroud Connection
(optional)

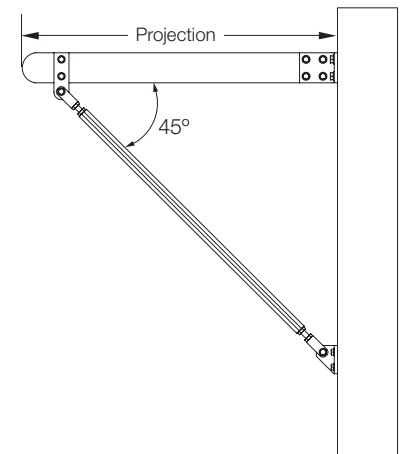

Strut Connection
(optional)