

ALL-LITE

EFK-430

Extruded Aluminum Louver
4" deep • 30° K-Blade

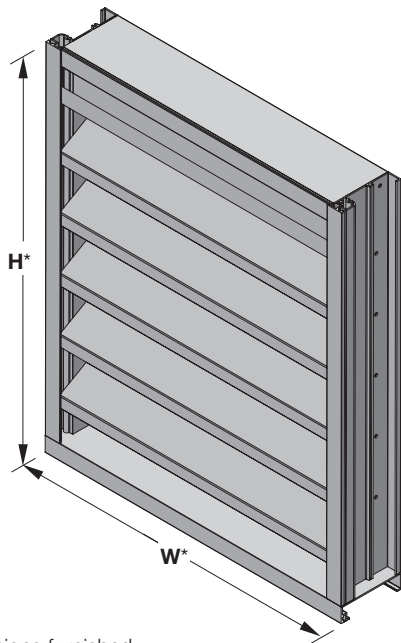

EFK-430

(standard)

*Louver dimensions furnished
approximately 1/2" (13) undersize.

The EFK-430 extruded aluminum louver is designed for intake and exhaust application where protection against water infiltration is not critical. The EFK-430 is well suited for special shape applications and is available with hidden mullions for a continuous blade appearance of multiple section assemblies. The EFK-430 is available in a wide array of anodized and painted finishes including custom color matching.

Standard Construction

Material: Mill finish 6063-T5 extruded aluminum

Frame: 4" deep × 0.081" thick (102 × 2) channel

Blades: 30° × 0.081" (2) thick K-style

Screen: 1/2" × 0.063" (12.7 × 1.6) expanded and flattened aluminum

Minimum Size: 4.5" × 8" (114 × 203)

Maximum Size:

Single section: 60" × 120" (1524 × 3048)
120" × 60" (3048 × 1524)

Multiple section: Unlimited

Ratings

Free Area: [48" × 48" (1219 × 1219) unit]: 9.6 ft² (0.89 m²)
59.6%

Performance @ Beginning Point of Water Penetration

Free Area Velocity: 1,002 fpm (5.09 m/s)

Air Volume Delivered: 9,619 cfm (4.54 m³/s)

Pressure Loss: 0.16 in.wg. (41 Pa)

Velocity @ 0.15 in.wg. Pressure Loss: 960 fpm (4.87 m/s)

Design Load: 30 psf

Options

■ Factory finish:

- High Performance Fluoropolymer
- Prime Coat
- Baked Enamel
- Clear Anodize
- Integral Color Anodize

■ Frame options:

- 1-1/2" (38) flange frame
- Custom-size Flange
- Stucco flange
- Glazing frame

■ Installation hardware

- Clip angles
- Continuous angles

■ Hidden vertical mullion

■ Welded construction

■ Alternate bird or insect screens

■ Insulated or non-insulated blank-off panels

■ Filter racks

■ Hinged frame

■ Subframe

■ Head and/or sill flashing

■ Burglar bars

■ Frame closure

■ Net OD (actual size)

5 year
warranty

NOTE: Dimensions in parentheses () are millimeters.
Information is subject to change without notice or obligation.

PERFORMANCE

EFK-430

Extruded Aluminum Louver
4" deep • 30° K-Blade

Free Area (ft²)

		Width (Inches)																		
		12	18	24	30	36	42	48	54	60	66	72	78	84	90	96	102	108	114	120
Height (Inches)	12	0.4	0.6	0.8	1.1	1.3	1.5	1.8	2.0	2.2	2.4	2.7	2.9	3.1	3.4	3.6	3.8	4.0	4.3	4.5
	18	0.6	1.0	1.4	1.8	2.2	2.5	2.9	3.3	3.7	4.1	4.5	4.8	5.2	5.6	6.0	6.4	6.8	7.1	7.5
	24	1.0	1.6	2.1	2.7	3.3	3.9	4.5	5.1	5.6	6.2	6.8	7.4	8.0	8.6	9.1	9.7	10.3	10.9	11.5
	30	1.2	2.0	2.7	3.4	4.2	4.9	5.7	6.4	7.1	7.9	8.6	9.3	10.1	10.8	11.6	12.3	13.0	13.8	14.5
	36	1.5	2.4	3.3	4.2	5.0	5.9	6.8	7.7	8.6	9.5	10.4	11.3	12.2	13.1	14.0	14.8	15.7	16.6	17.5
	42	1.7	2.8	3.8	4.9	5.9	7.0	8.0	9.1	10.1	11.1	12.2	13.2	14.3	15.3	16.4	17.4	18.4	19.5	20.5
	48	2.1	3.3	4.6	5.8	7.1	8.3	9.6	10.8	12.0	13.3	14.5	15.8	17.0	18.3	19.5	20.8	22.0	23.3	24.5
	54	2.3	3.7	5.1	6.5	7.9	9.3	10.7	12.1	13.5	14.9	16.3	17.7	19.1	20.5	21.9	23.3	24.7	26.1	27.5
	60	2.6	4.1	5.7	7.2	8.8	10.4	11.9	13.5	15.0	16.6	18.1	19.7	21.2	22.8	24.3	25.9	27.4	29.0	30.5
	66	2.9	4.7	6.4	8.2	9.9	11.7	13.5	15.2	17.0										
	72	3.2	5.1	7.0	8.9	10.8	12.7	14.6	16.5	18.4										
	78	3.4	5.5	7.6	9.6	11.7	13.7	15.8	17.9	19.9										
	84	3.8	6.0	8.3	10.6	12.8	15.1	17.4	19.6	21.9										
	90	4.0	6.4	8.9	11.3	13.7	16.1	18.5	20.9	23.4										
96	4.3	6.9	9.4	12.0	14.6	17.1	19.7	22.3	24.8											
102	4.6	7.4	10.2	12.9	15.7	18.5	21.3	24.0	26.8											
108	4.9	7.8	10.7	13.7	16.6	19.5	22.4	25.4	28.3											
114	5.1	8.2	11.3	14.4	17.4	20.5	23.6	26.7	29.8											
120	5.5	8.7	12.0	15.3	18.6	21.9	25.2	28.4	31.7											

Water Penetration

AMCA defines the beginning point of water penetration as the free area velocity at the intersection of a simple linear regression of test data and the line of 0.01 ounces of water per square foot of free area measured through a 48" x 48" louver during a 15 minute period. The AMCA water penetration test provides a method for comparing louver models and designs as to their efficiency in resisting the penetration of rainfall under specific lab conditions. We recommend that intake louvers are selected with a reasonable margin of safety below the beginning point of water penetration in order to avoid unwanted penetration during severe storm conditions.

Beginning Point of Water Penetration = 1,002 fpm

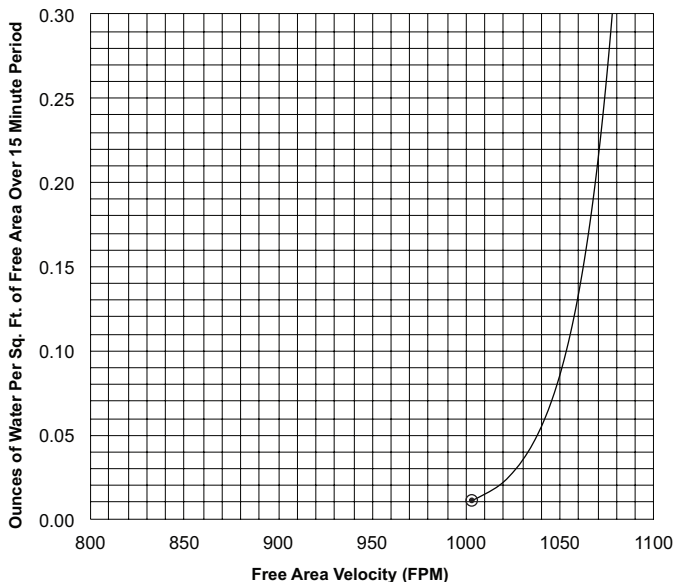

Pressure Loss

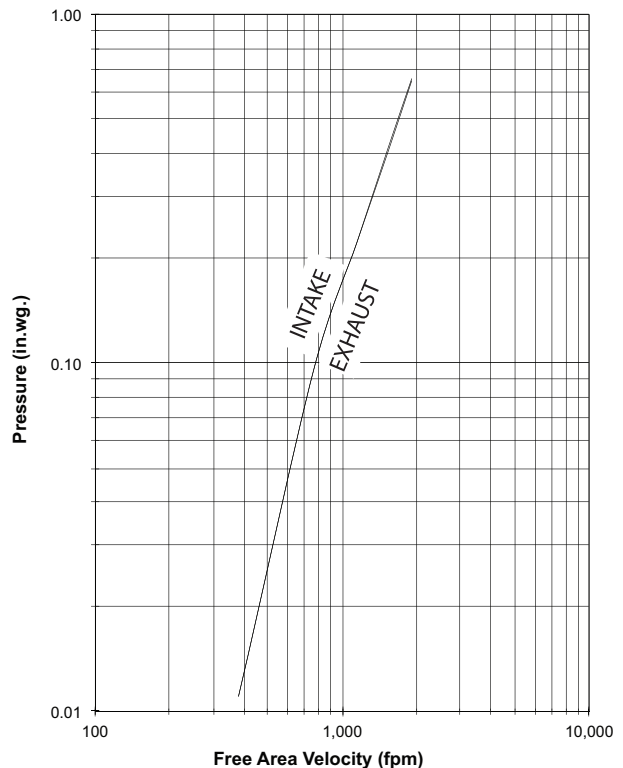

Louver Test Size = 48" x 48" (1219 x 1219)
Pressure loss tested in accordance with Figure 5.5 of AMCA Standard 500-L. Data corrected to standard air density.

EFK-430

Extruded Aluminum Louver
4" deep • 30° K-Blade

Attributes

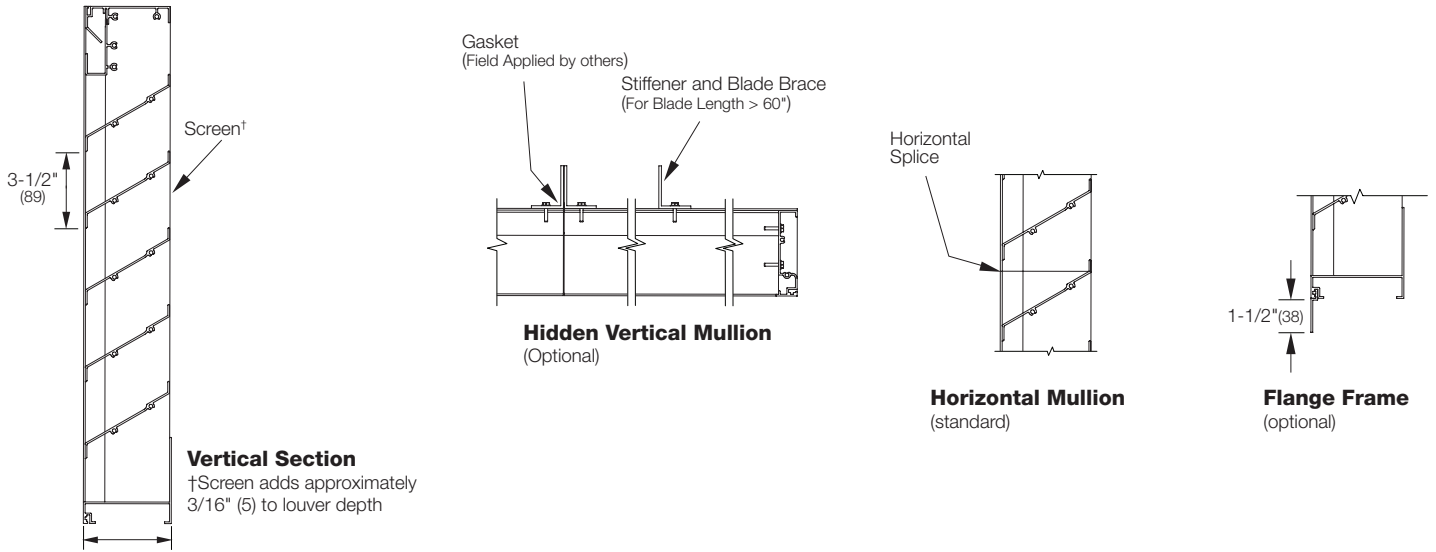

Supplemental Options

