

ALL-LITE

EBV-445

Extruded Aluminum Brick Vent
4" deep • 45° J-Blade

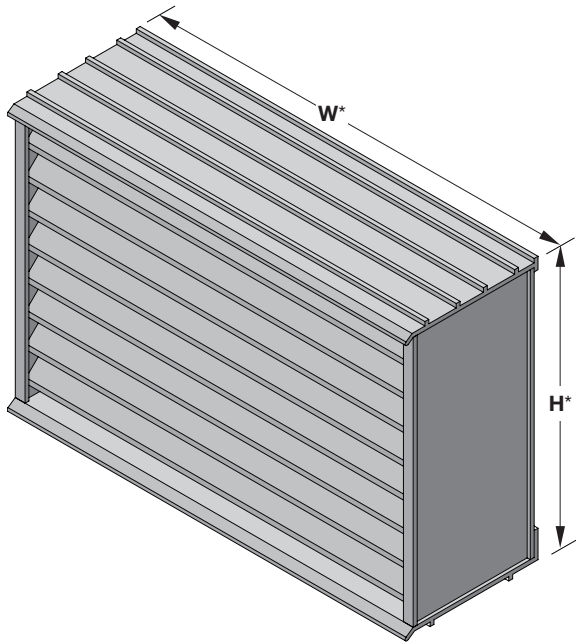

EBV-445

(standard)

*Fastener heads add a combined 1/4" (6) to the ordered width.

Standard Sizes (W × H)

8-1/8" × 2-3/8" (216 × 60)	16-1/2" × 2-3/8" (419 × 60)
8-1/8" × 4-3/4" (216 × 121)	16-1/2" × 4-3/4" (419 × 121)
8-1/8" × 7-3/4" (216 × 186)	16-1/2" × 7-3/4" (419 × 186)
12" × 2-3/8" (305 × 60)	16-1/2" × 15-3/4" (419 × 400)
12" × 4-3/4" (305 × 121)	24" × 2-3/8" (610 × 60)
12" × 7-3/4" (305 × 186)	24" × 4-3/4" (610 × 121)
12" × 11-3/4" (305 × 298)	24" × 7-3/4" (610 × 186)
15-5/8" × 7-3/4" (397 × 186)	32" × 7-3/4" (913 × 186)
15-5/8" × 15-3/4" (397 × 400)	48" × 7-3/4" (1219 × 186)

The EBV-445 brick vent is used primarily in new construction and incorporates 1/8" (3) mortar ribs at the top and bottom. Brick vents provide a permanent means of gravity ventilation for crawl spaces, hung ceilings, incinerator rooms, chimney flues, foundations, pipe spaces, and corridors and are not intended to protect against driven rain conditions.

Standard Construction

Material: Mill finish 6063-T5 extruded aluminum

Frame: 4" deep × 0.125" thick (102 × 3) with 1/8" (3) mortar ribs top and bottom (adds 1/4" to overall nominal height).

Blades: 45° × 0.125" (3) thick J-style

Screen: 18 × 14 mesh aluminum insect screen

Minimum Size: 4" × 2-3/8" (102 × 60)

Maximum Size: 48" × 24" (1219 × 610)

Options

■ Factory finish:

- Polyester Powder
- Baked Enamel
- Clear or Color Anodized, Class 1
- Prime Coat

Attributes

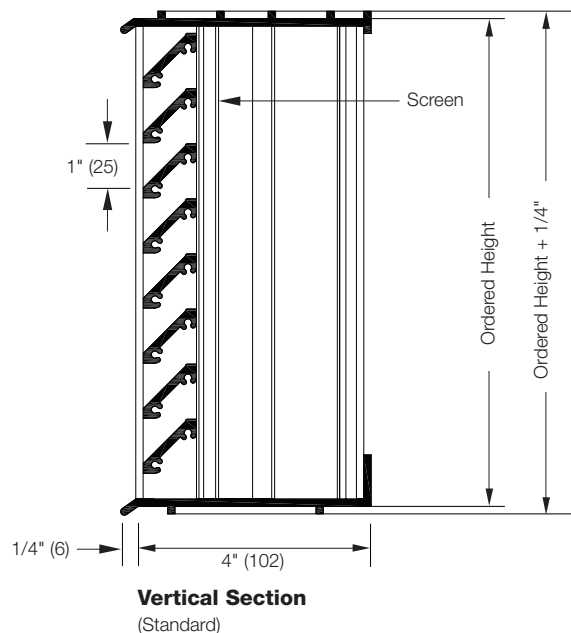

NOTE: Dimensions in parentheses () are millimeters.
Information is subject to change without notice or obligation.