

# ALL-LITE

## EBV-145

Extruded Aluminum Brick Vent  
1-1/2" deep • 45° J-Blade

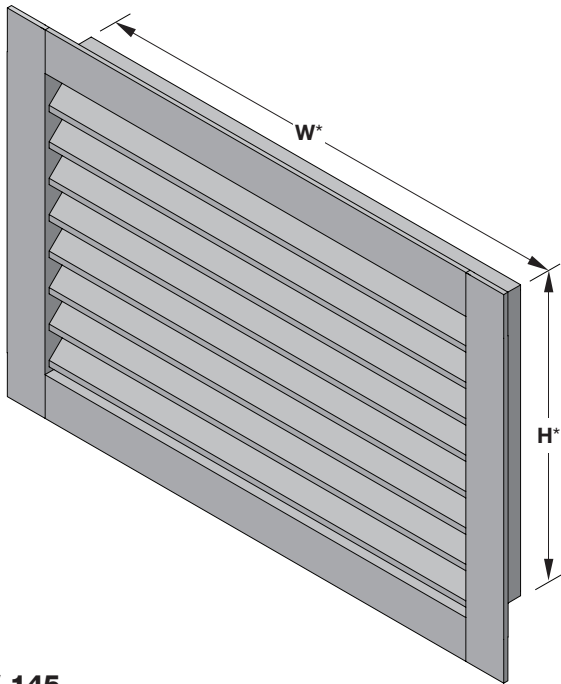

The EBV-145 brick vent is used primarily on renovation projects and incorporates a 1" (25) face flange. Brick vents provide a permanent means of gravity ventilation for crawl spaces, hung ceilings, incinerator rooms, chimney flues, foundations, pipe spaces, and corridors and are not intended to protect against driven rain conditions.

### Standard Construction

**Material:** Mill finish 6063-T5 extruded aluminum

**Frame:** 1-1/2" deep × 0.125" thick (38 × 3) with 1" (25) face flange

**Blades:** 45° × 0.125" (3) thick J-style

**Screen:** 18 × 14 mesh aluminum insect screen

**Minimum Size:** 4" × 2-3/8" (102 × 60)

**Maximum Size:** 48" × 24" (1219 × 610)

### Options

■ **Factory finish:**

- Polyester Powder
- Baked Enamel
- Clear or Color Anodized, Class 1
- Prime Coat

#### EBV-145

(standard)

\*Fastener heads add a combined 1/4" (6) to the ordered width

### Standard Sizes (W × H)

8-1/8" × 2-3/8" (216 × 60)	16-1/2" × 2-3/8" (419 × 60)
8-1/8" × 4-3/4" (216 × 121)	16-1/2" × 4-3/4" (419 × 121)
8-1/8" × 7-3/4" (216 × 186)	16-1/2" × 7-3/4" (419 × 186)
12" × 2-3/8" (305 × 60)	16-1/2" × 15-3/4" (419 × 400)
12" × 4-3/4" (305 × 121)	24" × 2-3/8" (610 × 60)
12" × 7-3/4" (305 × 186)	24" × 4-3/4" (610 × 121)
12" × 11-3/4" (305 × 298)	24" × 7-3/4" (610 × 186)
15-5/8" × 7-3/4" (397 × 186)	32" × 7-3/4" (913 × 186)
15-5/8" × 15-3/4" (397 × 400)	48" × 7-3/4" (1219 × 186)

### Attributes

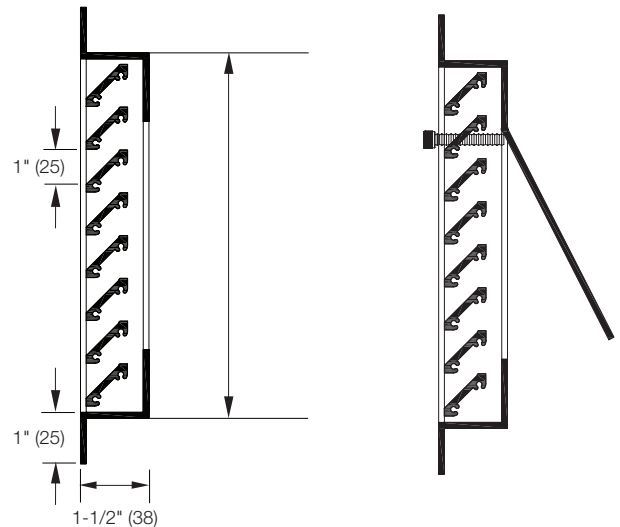

**Vertical Section**  
(Standard)

**Flap Blade Damper**  
(Optional)

**NOTE:** Dimensions in parentheses ( ) are millimeters.  
Information is subject to change without notice or obligation.